

HYPROLYSER[®] iSEC[®]-1 MODULAR 3-6

IN-SITU SODIUM HYPOCHLORITE GENERATION SYSTEM

Dimensions

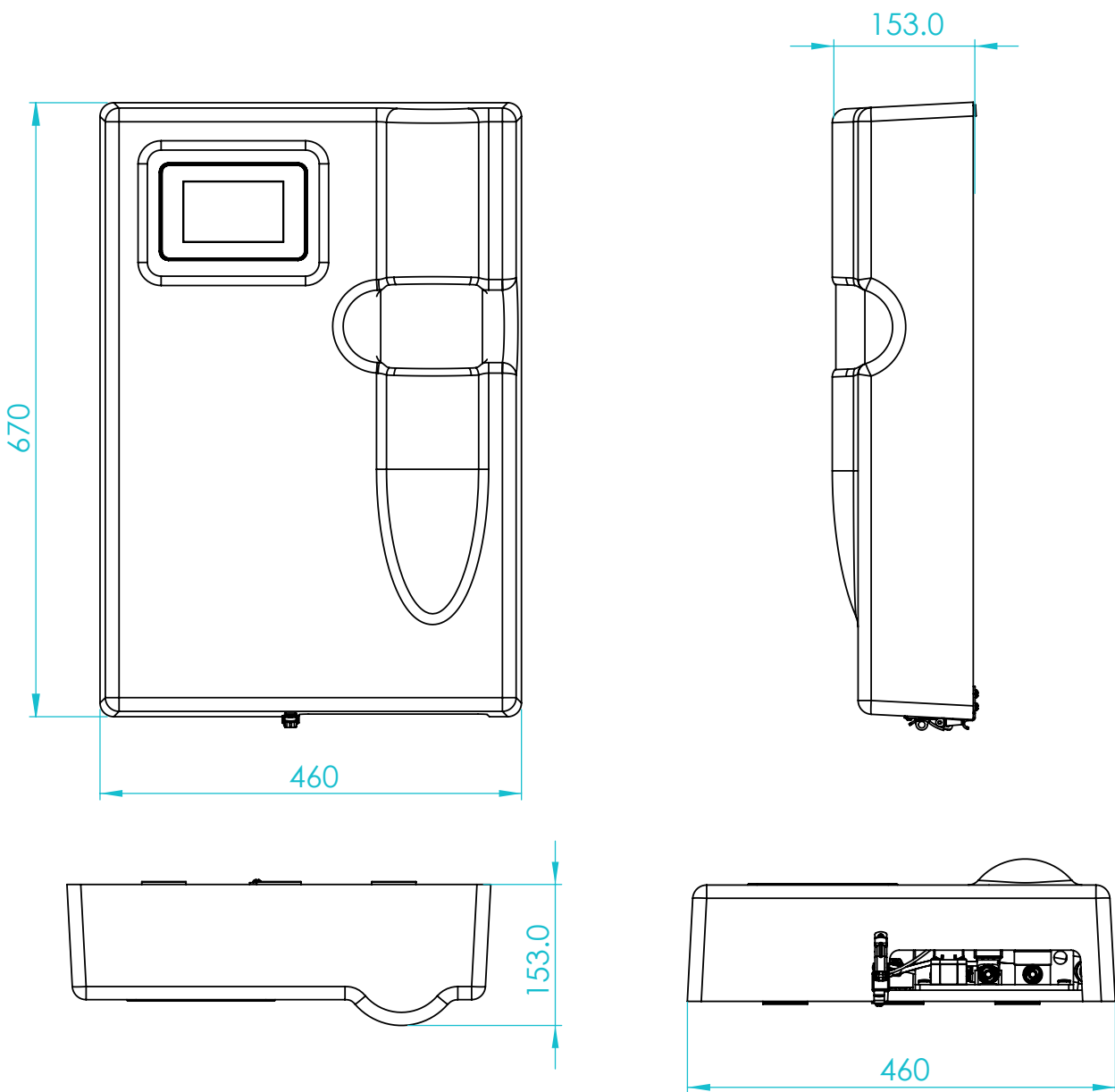

Features

Control

- IP65 sealed power supply unit
- Low demand generation mode
- Softener cartridge capacity monitoring and alert
- Precise volumetric softened water & vacuum brine feed
- Electrolyser temperature monitoring
- Water meter input with programmable dosing pulse output
- Alarm & event logs

- Service reminders
- Live process & IO mimics

Inputs

- External tank level control
- Remote inhibit
- E-Stop
- Batch control
- Site water meter
- Site water flow signal

Outputs

- Alarm signal contact
- Programmable relay output
- Modbus RTU/TCP
- VNC
- Email alerts
- MQTT

Schematics

Item	Feature Equipment
1	Touchscreen HMI
2	Product tank level switch
3	Product tank
4	Electrolyser
5	Product outlet
6	Drain/Sample valve
7	Brine inlet
8	Softened water inlet
9	Water flow meter
10	DC Power supply
11	Brine eductor

Specifications

Model		3	6
Cl ₂ Capacity	g/h	3	6
Cl ₂ Concentration	mg/L	500	1500
NaClO Solution	L/h	6	4
Inlet Water Specification			
Pressure	MPa	0.2 - 0.3	
Temperature	°C	8 - 23	
Hardness (CaCO ₃)	mg/L	< 20	
Hardness	°dH	< 1	
Turbidity	NTU	< 5	
pH	-	6.5 - 8	
Particle size	µm	< 100	
Iron	µg/L	< 200	
Manganese	µg/L	< 10	
Fluoride	mg/L	< 2	
Free chlorine	mg/L	< 1	
Environmental			
Protection class	IP	65	
Ambient temperature	°C	5-40	
Humidity	% RH	95	
Electrical Data			
Supply voltage	V~	110-230V~	
Frequency	Hz	50 - 60	
Max. rated power	VA	75	90
Consumption			
Power (kWh/kg Cl ₂)	kWh	5.0	
Salt (kg/kg Cl ₂)	Kg	3.0	
Connections			
Water inlet	-	8mmOD push-fit	
Brine inlet	-	8mmOD push-fit	
Product outlet	-	12mm UPVC union OR DN6/12 hose connector	
Soft water sample valve	-	15mm push fit	
PRV	-	R1/2 or G3/4	
Size Data			
Weight	Kg	17	
Dimensions	mm	670 (H) x 460 (W) x 153 (D)	

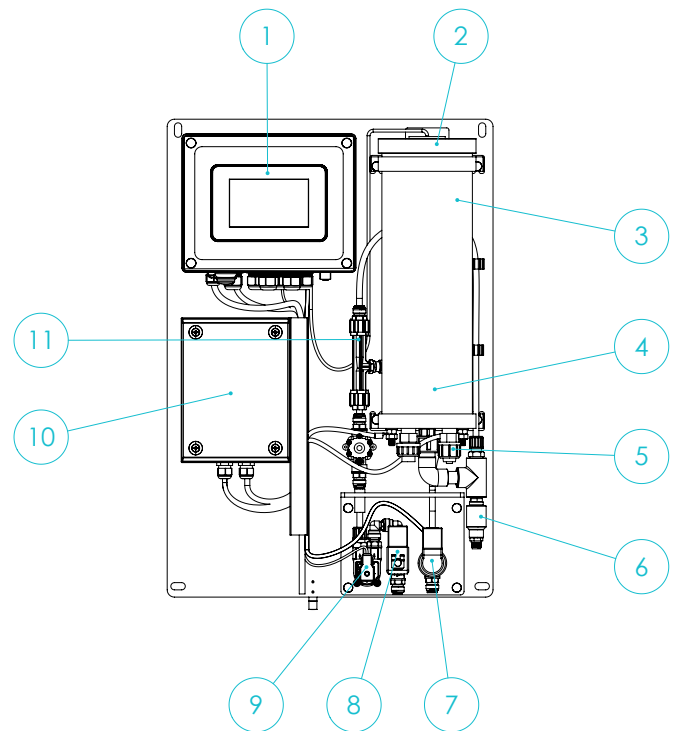

Gaffey Technical Services Ltd.
Unit 3a Newhouse Road,
Huncoat Business Park,
Accrington, Lancashire BB5 6NT

Gaffey Technical Services Ltd. email info@gaffeytechnology.com
call **+44 (0) 1254 350180** or visit www.gaffeytechnology.com

a member of

BRITISH
WATER

MADE IN
BRITAIN

QMS ISO 9001 : 2015
REGISTERED